

Model: RC 1200 EGP

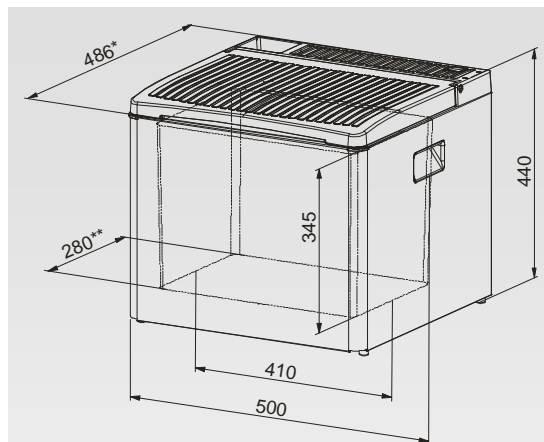

***Gas connection not included**
(gas connection max: + 35 mm)
****Evaporator plate not included**
(evaporator plate: -50 mm)

Technical data

| | |
|--|--|
| Gross volume | 41,20 litres (net 40,20 l.) |
| Net weight | 16 kg |
| Outside dimensions (nominal) Height x Width x Depth | 440 x 500 x 486 mm |
| Inside dimensions (nominal) Height x Width x Depth | 345 x 410 x 280 mm |
| Packaging dimensions - Height x Width x Depth - Volume - Weight | 510 x 560 x 565 mm 0,161 m ³ 19 kg |
| Body | Durable plastic-coated cabinet ABS plastic moulded parts Metallic rear cover CFC and HCFC free insulation |
| Colour | Blue cabinet, Light gray grill and handles, Light blue lid |
| Cooling unit | Absorption Virtually silent |
| Operation | 3 ways (12 V / 230 V / gas) |
| Ice making facility | 6 cubes covered ice tray Removable ice tray Ice cubes even at 32°C |

| | |
|--|--|
| Tilt insensitivity | 3 degrees |
| Consumption* - Electricity - 12 V - Gas** - Gas** | 1,60 kWh/24h approx. 170 Ah/24h approx 266 g/24h approx max. 200 g/24h approx min. |
| <i>(*Average consumption at 25°C ambient according to ISO standards)</i> <i>(**Average consumption for 30 mbar propane)</i> | |
| Regulation | Thermostat on 230 V Valve 3 positions on gas |
| Gas operation | Piezo igniter |
| Electricity operation | 85 W max. input 12 V / 230 V |
| Cable length | 230 V : 1,5 m / 12 V : 2,5 m |
| Other features | Special flat designed lid with shoulder Robust plastic coated cabinet Integrated carrying handles 12 V / 230 V cable holder |
| Variants | - |
| Factory certifications | ISO 9001 - ISO 14001 |
| Product certifications | SEMKO - SP |